

SP-DC

Capacity

10 - 15 - 20 - 25 - 30 - 35 - 40 - 50 t

DIGITAL Compression load cell

Up to 4000 divisions OIML-R60

Fully stainless steel

Fully welded. Protected against humidity IP-68 (EN 60529)

Software corner adjustment

Plug & Weigh System, calibrated from factory

IP-68 Connectors

Available cable with metallic cover

Technical Data

Accuracy class	C3-C4
Vmin	Emax/15000
Excitation Voltage	8±15 V
Input Resistance	570 ± 3 Ω
Current consumption	35 mA
Transmission speed	100 kHz (Max)
Conversions per second	40 s ⁻¹
Internal resolution	24 bits
Temperature limits OIML R60	-10°C / +40°C
Insulation resistance	> 5000 M Ω



Certificate
N° E-02.02.C02



R60/2000-ES1-10.01



SENSOCAR

Tel.: 34 93 780 44 99

Fax: 34 93 780 39 72

www.sensocar.com

comercial@sensocar.com

Connections

- 1 +Vcc (Red)
- 2 SCL (Green)
- 3 SDA (White)
- 4 GND (Black)



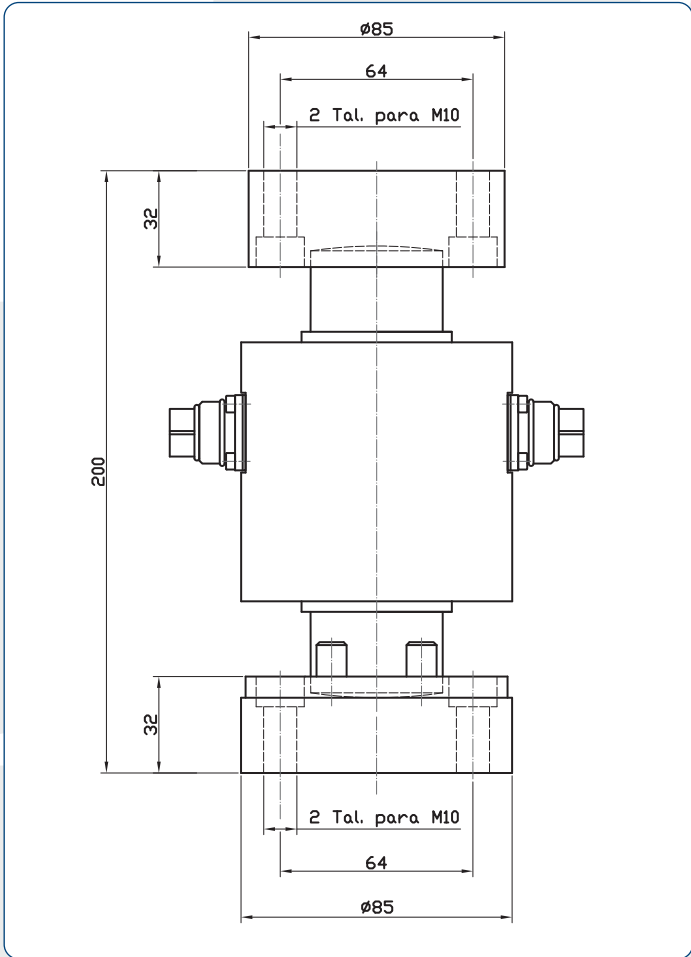

Bases Accessory SP

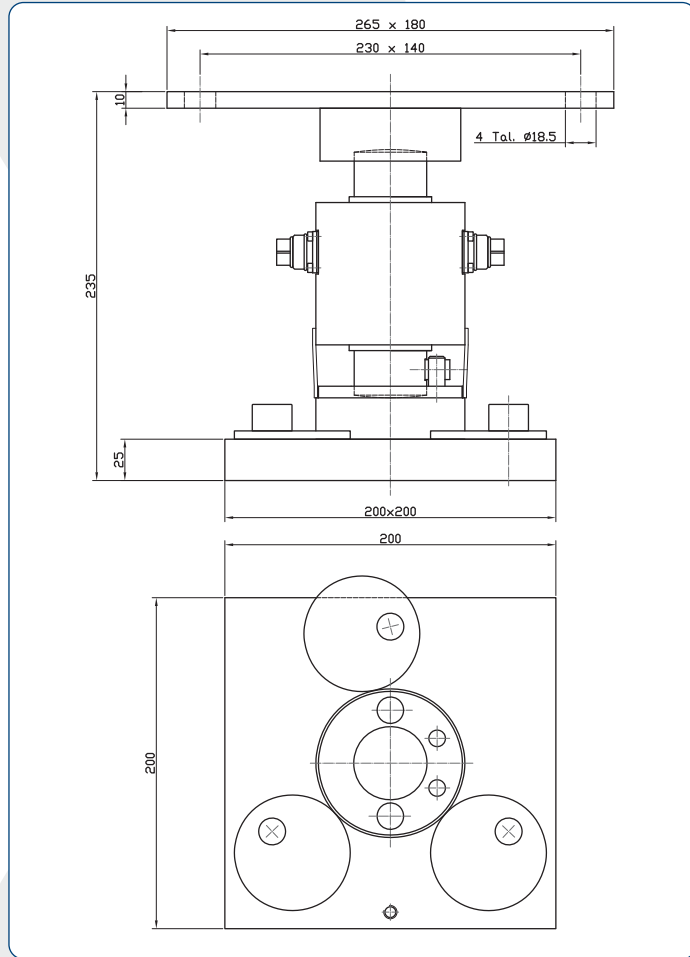

Support Accessory SP

